

S102XK™

FUEL WATER SEPARATOR SENSOR KIT



FITMENT ADVICE

- Install S100X in-engine module away from heat sources, e.g., turbo, exhaust pipes, etc.
- Do not install a fuse tap into a fuse slot that already has another circuit tapped off it to avoid overloading the circuit and blowing the fuse.
- Ensure that red wire (power) is connected to a power source, and not to a ground source.
- Ensure that black wire (ground) is connected to a ground source, and not to a power source.
- Ensure that installation turns are not exceeded when fitting Ryco water in fuel sensor to filter (Ryco attachment Max turns after gasket touch = 1.5 turns, M8 attachment = 1.5 turns & 3/8" attachment = 1.25 full turn).
- Ensure that water in fuel sensor harness is connected to the main harness using the Deutsch connector with the blue heat shrink

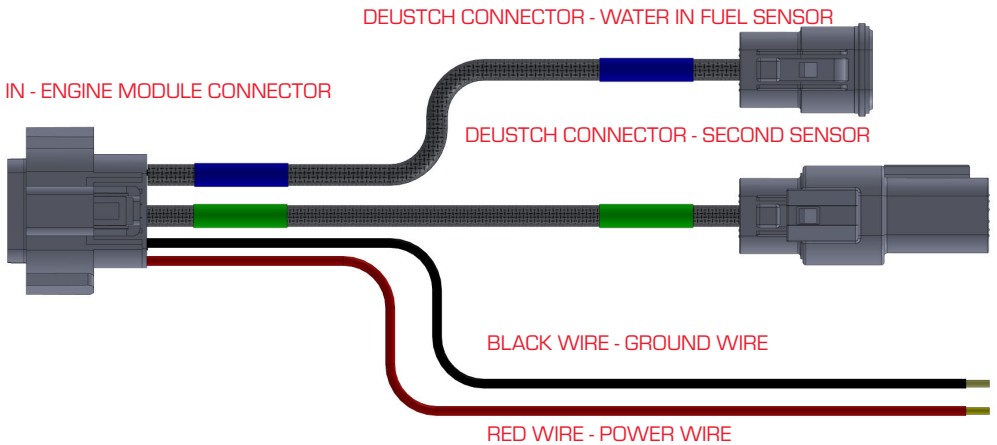

FIGURE 1
MAIN HARNESS



FIGURE 2
WATER IN FUEL SENSOR HARNESS

S102X FUEL WATER SEPARATOR SENSOR

Tools/material required: grease/lubricant

Supplied items required: Sensor attachment gasket, sensor attachment, o-ring, water in fuel sensor, metal clip

This Bluetooth kit comes with 3 sensor attachments to fit to most popular fuel water separators using Ryco drain bowl thread, M8 thread and 3/8" thread.

See diagram below FIG. 3 for what gasket and sensor attachment to use for your installation:

Ryco drain bowl thread
or filter which uses
similar thread size

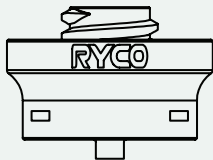
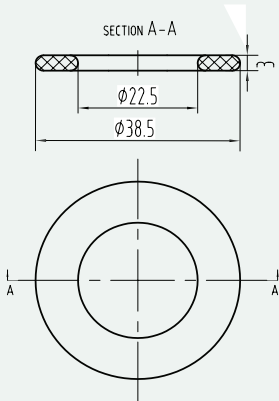

Fitment specification :
After gasket touch turn
1 to 1 1/2 turns.

M8 Drain Bowl Thread

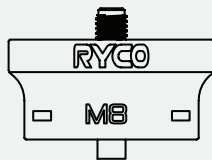
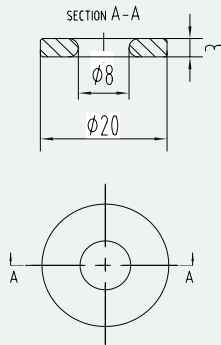

Fitment specification
into filter drain thread :
After gasket touch turn
1 full turn to 1 1/4 turn.
**DO NOT EXCEED 1 1/4
TURNS TO PREVENT
DAMAGE TO THREAD.**

3/8" Drain Bowl Thread

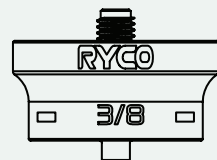
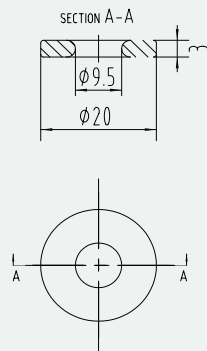

Fitment specification :
After gasket touch turn
1 to 1 1/2 turns.

FIGURE 3
SENSOR ATTACHMENTS AND GASKET

S102X FUEL WATER SEPARATOR SENSOR

- 1 Lubricate O-ring (No.3) with a grease or oil then fit onto the water in fuel sensor (No.4), in the valley section shown by arrow in (see FIG. 4).
- 2 Proceed to install water in fuel sensor (No.4) into your chosen sensor attachment (No.2), this is a push fit install. Make sure the o-ring (no.3) is lubricated to make this installation easier. It is by design to be a very tight fit.
- 3 Proceed to install the metal clip (No.5) into the sensor attachment by inserting each pin of the clip into the front face of the sensor attachment (side which has its thread type embossed). Keep pushing until the clip has gone through and out the slots on the opposite side of the sensor attachment.
- 4 Fit sensor attachment gasket onto the thread of the sensor attachment.
- 5 Install assembled water in fuel sensor onto your filter following the correct fitment specification:
(Ryco attachment Max turns after gasket touch = 1.5 turns, M8 attachment = 1.5 turns & 3/8" attachment = 1.25 full turn).

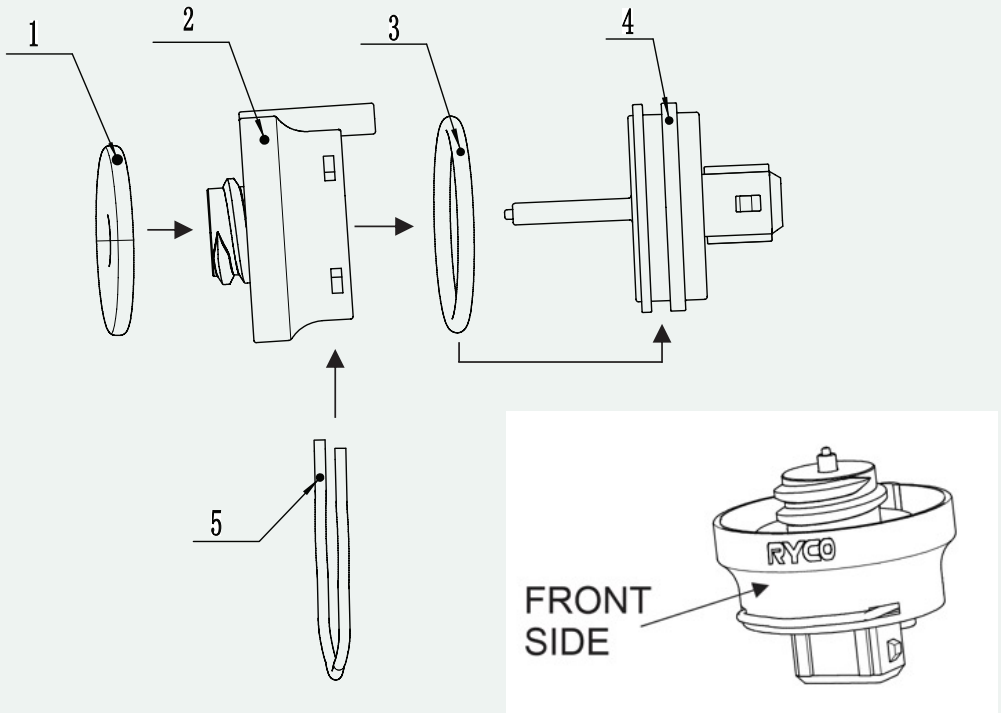

FIGURE 4

S102X FUEL WATER SEPARATOR SENSOR

- 6 Connect the sensor harness to assembled water in fuel sensor using the connector end shown in FIG 5.
- 7 Route the sensor wire harness neatly around engine bay, avoiding high-temperature areas, until you reach the main wire harness. Then connect Deutsch connector from the sensor wire harness to the Deutsch connector on the main wire harness which has the blue heat shrink around is wire conduit, as shown in FIG 6. Excess wire on the wire harness can be coiled up and zip tied to the side of the vehicle to create a cleaner look.

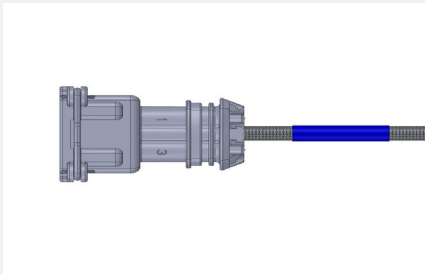

FIGURE 5

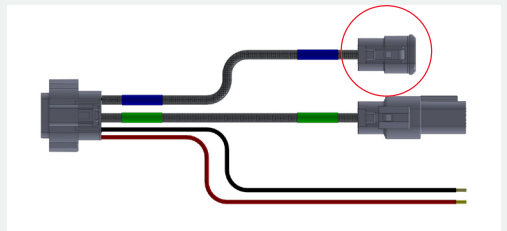

FIGURE 6

S102X FUEL WATER SEPARATOR SENSOR

Tools/material required: Heat gun, wire crimp tool, wire stripper tool (optional)

Supplied items required: Wiretap, fuse, main wire harness, solder sleeve, ring terminal, zip ties

- 1 Open the engine fuse panel and find a suitable fuse slot that is powered on accessories. An example of this is, you can confirm that a fuse is powered on accessories by using a multimeter; setting it to voltage, and putting the power pin on the multimeter onto the metal exposed section of the fuse, and the black pin from the multimeter onto a ground source such as bolt/nut in the engine bay or negative terminal of the vehicle battery, when ignition key is turned to accessories or power on you should see voltage across this fuse - whereas when ignition key is turned to fully off position you should see no voltage. Ensure that the fuse you will be adding the fuse tap is not already having additional circuit tapped of it, or else you may overload this circuit.
- 2 When a suitable fuse slot is found, select the correct fuse tap that matches that slot's fuse type.
- 3 The bottom fuse slot on fuse tap is for the original fuse that was housed in that slot, install original fuse into bottom slot. The top fuse slot on the fuse tap is for the S100X module, install the correct supplier 5-amp fuse into this slot. Install the fuse that was in the original fuse slot, which is being tapped for power, into the bottom fuse tap slot. If no fuse was in this slot, install a 5-amp fuse into the bottom slot.
- 4 The fuse tap wire is now ready to be installed into the main wire harness. Using the supplied solder sleeve (noting that the solder sleeve has a small inner diameter side and bigger inner diameter side) put the smaller inner diameter side onto the red (powerwire from the main wire harness.)



FIGURE 1

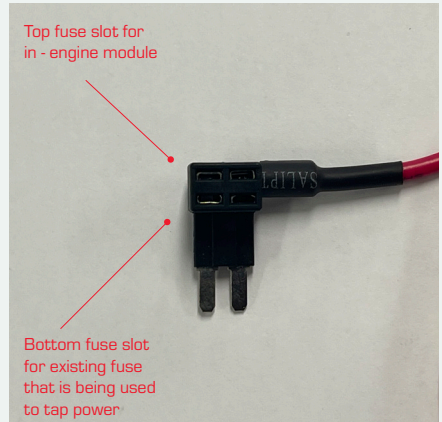

FIGURE 2

S102X FUEL WATER SEPARATOR SENSOR

- 5 Remove the excess wire insulation from both the red (power) wire on the main wire harness, and the excess insulation on the fuse tap wire. Noting that if you require more bare wire length, you can use a wire stripper to remove further insulation from the wire.

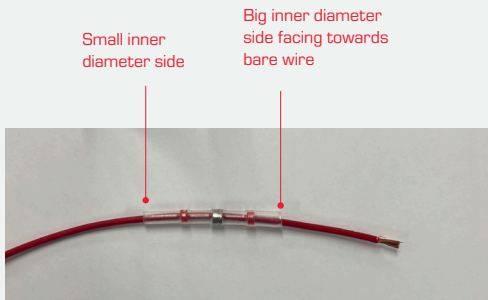

FIGURE 3

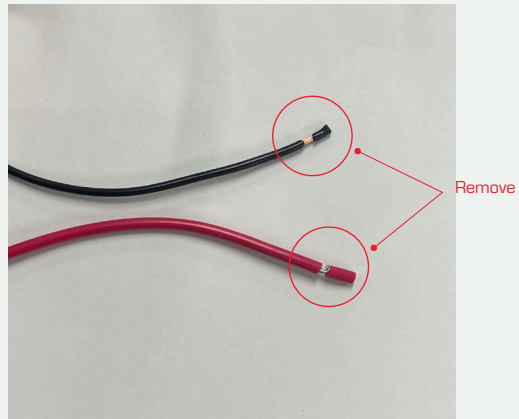

FIGURE 4

S102X FUEL WATER SEPARATOR SENSOR

- 6 Push and twist together the bare end wires from the end of the fuse tap wire and red (power) wire from the main harness.
- 7 Move solder sleeve along wire so that the low temperature solder is located where the fuse tap wire and main harness red (power) wire are twisted together.
- 8 Using heat gun or other heat source on solder sleeve until the clear sections of solder sleeve have melted and shrunk sealing the wires, as well as the low temperature solder has bonded with the exposed wires.
- 9 Remove excess insulation from black (ground) wire on main wire harness.
- 10 Install terminal ring onto black (ground) wire on main wire harness by inserting bare wire from black (ground) wire into the terminal rings crimp section, then using crimp tool (suitable for FLRY-B 0.75 wire) crimp terminal ring section to wire. Then proceed to use a heat source on the wire end of the terminal ring connector until the shrink wrap section of the ring terminal melts and shrinks, sealing the wire.



FIGURE 5



FIGURE 6



FIGURE 7



FIGURE 8

S102X FUEL WATER SEPARATOR SENSOR

- 11 Main wire harness can be zip tied out of the way or to side of the engine bay using supplied zip ties.



FIGURE 10



FIGURE 11



FIGURE 12

IN-ENGINE MODULE INSTALLATION

Tools/material required: socket wrench or spanner (depending on fitment choice)

Supplied items required: : in-engine module.

- 1 Find a suitable location to install the S100X in-engine module. **For the most optimal Bluetooth connectivity, it is advised to install this module up high in the engine bay, and as close to the firewall as possible.** This location should not be near high-temperature section of the vehicle, e.g., turbo or exhaust pipes. There are two holes on the in-engine module that can be used for mounting on bolts and being tightened up by installing nuts.
- 2 Image below FIG.1 and 2 are installations of the S100X in-engine module in different vehicles.

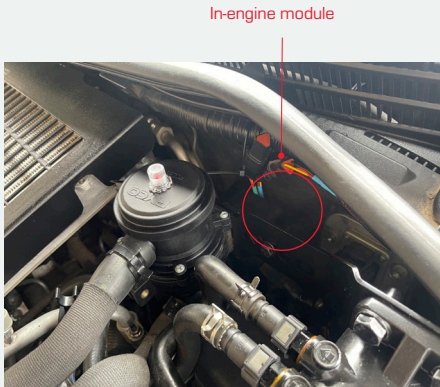

FIGURE 1



FIGURE 2

HOW TO CONNECT THE RYCO CONNECT APP TO THE SENSOR

- 1 Install Ryco Connect phone app to your mobile phone from the app store.
- 2 Turn on the vehicle to allow the in-engine module to be powered (note this may take a minute to fully power up and be detectable by Bluetooth).
- 3 Open the Ryco Connect phone app.
- 4 Upon opening the Ryco connect app for the first time, it will ask for permissions such as allow location services, bluetooth and operate while in background. press allow/approve, as this app requires this permission to run correctly while app is in phones background. noting that no location data is collected or stored by this app.
- 5 The app will then proceed to search for the in-engine module to connect to.
- 6 If the app is unable to find the in-engine module, it could be due to the in-engine module not fully powered yet. You may need to give the in-engine module a minute or two, to power up. Alternatively, check that all the wire harness connectors are connected correctly. The first time opening the app, you will need to press the add sensor button and follow the steps to connect to the in-engine module and water in fuel sensor.



FIGURE 1



FIGURE 2



FIGURE 3

HOW TO CONNECT THE RYCO CONNECT APP TO THE SENSOR

- 7 Once a connection is made to the in-engine module, it will detect the water in fuel sensor, press confirm.
- 8 The dashboard will then show any sensor connected with this app. Press START MONITOR to begin logging data from this sensor in the app.



FIGURE 4

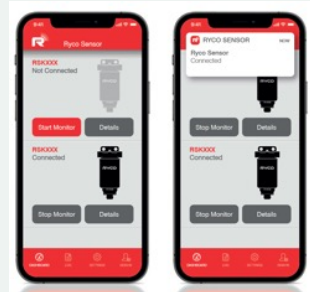

FIGURE 5

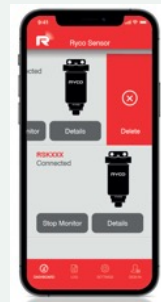

FIGURE 6

HOW TO CONNECT THE RYCO CONNECT APP TO THE SENSOR

- 9 You can swipe a sensor the left then press delete to remove a sensor from this screen.
- 10 Pressing the LOG button in the menu will bring you to a screen showing all logged data from the sensor connected to the in-engine module. You can swipe to the left and press delete to remove logged data from this list.
- 11 If you wish to connect to a new device, you can press SETTINGS from the menu bar and then press ADD NEW DEVICE.
- 12 From the settings screen you can also register your S102XK device, clear logs, search the help contents, contact Ryco, check notifications and privacy policy as well as delete your registered account.



FIGURE 7

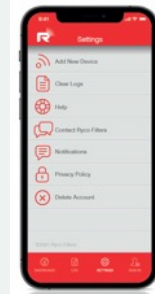

FIGURE 8

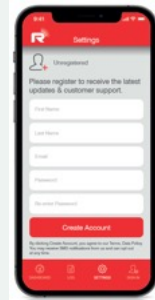

FIGURE 9

